

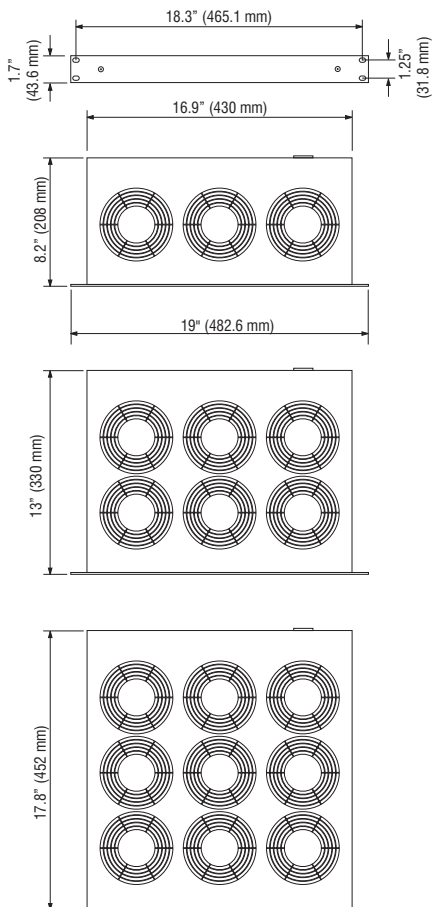

- High air volume**
- Long service life**
- Easy installation and connection**
- Function control light**
- Optional integrated thermostat**

The LE 019 is a compact high performance fan tray for forced circulation of air in enclosures and for cooling of 19" rack mount applications. Natural convection is improved and the formation of hot zones is prevented. Also available with integrated thermostat (see photo).



Technical Data

Axial fans, ball bearing	service life 50,000h at 25°C (65% RH) fan body aluminium, rotor plastic
Material	front panel aluminium, bright anodised casing steel sheet, electrogalvanized
Optical indicator	integrated in front panel
Connection	power inlet on rear of casing, plug included (no cable)
Mounting position	horizontal (direction of air upward)
Operating / Storage temperature	-45 to +70°C (-49 to +158°F)
Protection type	IP20
Protection class	I (grounded)
Approvals	UL File No. E234324

Note

The use of a thermostat, whether integrated or external, is recommended.

When using a fan tray with integrated thermostat, an additional thermostat (e.g. KT 011 Part No. 01141.0-00) may be used if it is desired to switch a signal device should the enclosure interior temperature rise above a set limit (e.g. in case of fan failure).

For models without integrated thermostat, the use of a dual thermostat (e.g. ZR 011 Part No. 01176.0-00) provides the same overheat protection, i.e. one thermostat to control the fan tray operation, one thermostat for a signal device.

Part No.	Model	No. of fans	Operating voltage	Air flow, free blowing	Power consumption	Average noise level (DIN EN ISO 4871)	Speed (rpm ⁻¹)	Static pressure	Weight (approx.)
01930.0-00	w/out thermostat	3	230VAC, 50Hz ¹⁾	286 cfm (486m ³ /h)	45W	55 db (A)	2600 min ⁻¹ (50Hz)	74Pa	6.6 lbs. (3.00kg)
01930.1-00	w/ thermostat (0 to 60°C)	3	230VAC, 50Hz ¹⁾	286 cfm (486m ³ /h)	45W	55 db (A)	2600 min ⁻¹ (50Hz)	74Pa	7.5 lbs. (3.40kg)
01931.0-00	w/out thermostat	3	120VAC, 60Hz	339 cfm (576m ³ /h)	45W	55 db (A)	2900 min ⁻¹ (60Hz)	88Pa	6.6 lbs. (3.00kg)
01931.1-00	w/ thermostat (0 to 60°C)	3	120VAC, 60Hz	339 cfm (576m ³ /h)	45W	55 db (A)	2900 min ⁻¹ (60Hz)	88Pa	7.5 lbs. (3.40kg)
01940.0-00	w/out thermostat	6	230VAC, 50Hz ¹⁾	572 cfm (972m ³ /h)	90W	57 db (A)	2600 min ⁻¹ (50Hz)	74Pa	11.7 lbs. (5.30kg)
01940.1-00	w/ thermostat (0 to 60°C)	6	230VAC, 50Hz ¹⁾	572 cfm (972m ³ /h)	90W	57 db (A)	2600 min ⁻¹ (50Hz)	74Pa	12.5 lbs. (5.70kg)
01941.0-00	w/out thermostat	6	120VAC, 60Hz	678 cfm (1152m ³ /h)	90W	57 db (A)	2900 min ⁻¹ (60Hz)	88Pa	11.7 lbs. (5.30kg)
01941.1-00	w/ thermostat (0 to 60°C)	6	120VAC, 60Hz	678 cfm (1152m ³ /h)	90W	57 db (A)	2900 min ⁻¹ (60Hz)	88Pa	12.5 lbs. (5.70kg)
01950.0-00	w/out thermostat	9	230VAC, 50Hz ¹⁾	858 cfm (1458m ³ /h)	135W	58 db (A)	2600 min ⁻¹ (50Hz)	74Pa	17.2 lbs. (7.80kg)
01950.1-00	w/ thermostat (0 to 60°C)	9	230VAC, 50Hz ¹⁾	858 cfm (1458m ³ /h)	135W	58 db (A)	2600 min ⁻¹ (50Hz)	74Pa	17.4 lbs. (7.90kg)
01951.0-00	w/out thermostat	9	120VAC, 60Hz	1017 cfm (1728m ³ /h)	135W	58 db (A)	2900 min ⁻¹ (60Hz)	88Pa	17.2 lbs. (7.80kg)
01951.1-00	w/ thermostat (0 to 60°C)	9	120VAC, 60Hz	1017 cfm (1728m ³ /h)	135W	58 db (A)	2900 min ⁻¹ (60Hz)	88Pa	17.4 lbs. (7.90kg)

¹⁾ air volume increases by 15% when operating 230VAC filter fans at 60Hz

Specifications are subject to change without notice. Suitability of this product for its intended use and any associated risks must be determined by the end customer/ buyer in its final application.